

VLT-230

Standard Electric Fowler Bed



BASE

Frame of feet with tubes 30 x 70 x 1.50 mm and PVC finishing in the four feet.

MATRESS PLATFORM

Articulable, it is made of perforated steel plate coated tube.

SHOCKHOLDERS

High impact rotating bumpers, made of polyethylene, located at the four corners of the bed ("Roller Bumpers").

HEADBOARD AND FOOTBOARD

Removable, they are blown in high-density polyethylene.

SIDERAILES

Articulated side rails in painted round tube. Optional: stainless steel.

MOVEMENTS

It has fowler and trendelenburg movements. The fowler movements are commanded by an electric motor with wire remote control, while the trendelenburg movement is activated by a gas shock absorber system, allowing quick and total bed inclination.

CASTERS

4" casters, all with brakes.

PAINTING

Powder electrostatic painting, with anticorrosive efficiency through phosphatization.

OPTIONALS

- IV Pole.

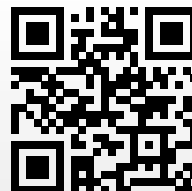
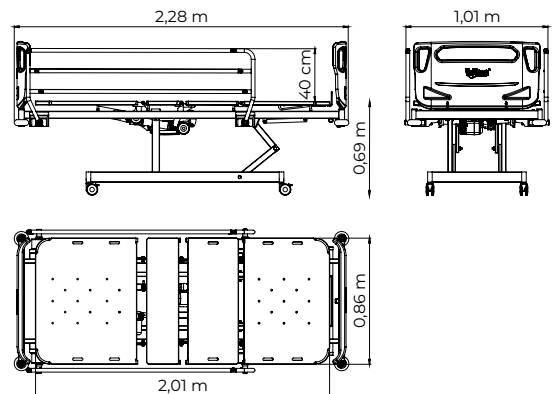

ValliTech
MÓVEIS HOSPITALARES

+55 41 3665.5700 | vallitech.com.br