

# VLT-231

## Electric Fowler Bed



**MATRESS PLATFORM**  
In perforated steel plate.

**SHOCKHOLDERS**  
High impact rotating bumpers, made of polyethylene, located at the four corners of the bed ("Roller Bumpers").

**HEADBOARD AND FOOTBOARD**  
Removable, blown in high-density polyethylene.

**SIDERAILS**  
Articulated side rails in painted round tube. Optional: stainless steel.

**MOVEMENTS**  
It has an electric fowler movement commanded by a wired remote control.

**CASTERS**  
4" casters, all with brakes.

**PAINTING**  
Electrostatic powder coating, with anticorrosive efficiency through phosphatization.

**OPCIONAIS**  
• IV Pole.

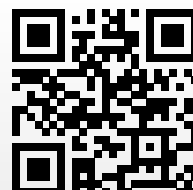
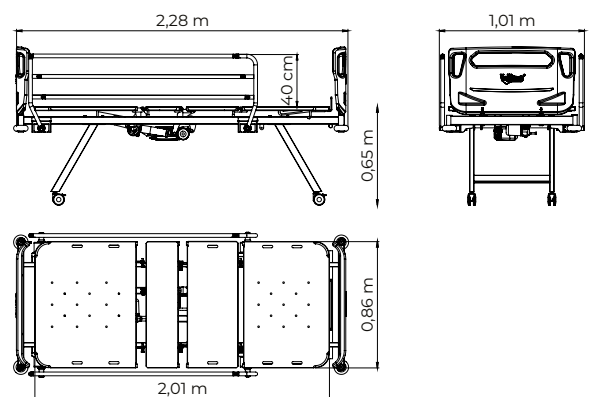

**ValliTech**  
MÓVEIS HOSPITALARES

+55 41 3665.5700 | [vallitech.com.br](http://vallitech.com.br)